



UNDERCOUNTER REFRIGERATORS

SERVING THE FOOD INDUSTRY SINCE 1951



Aurora Undercounter Refrigerators

ITEM:	59054	59093	59091
MODEL:	RE-CN-0006E-HC	RE-CN-0015E-HC	RE-CN-0017E-HC



27" wide
59054
RE-CN-0006E-HC



60" wide
59093
RE-CN-0015E-HC



72" wide
59091
RE-CN-0017E-HC

The perfect solution to add cold storage space for frozen products and ingredients conveniently within reach

FEATURES:

- Stainless steel interior and exterior
- Refrigeration system keeps food at safe
- Self-closing doors with 90 degree stayopen feature
- Adjustable heavy-duty PVC coated shelves
- Digital control system makes it easy to adjust temperature set point and defrost frequency
- Hydro-carbon R290 refrigerant, which is environmentally friendly and more efficient

Telephone: 1-800-465-0234

Fax: (905) 607-0234

Email: sales@omcan.com

Website: www.omcan.com



Authorized Dealer



WARRANTY
2 YEARS PARTS AND LABOUR
5 YEARS ON COMPRESSOR

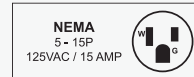

(Version 2023.10)

Page 1 / 4

TECHNICAL DRAWING

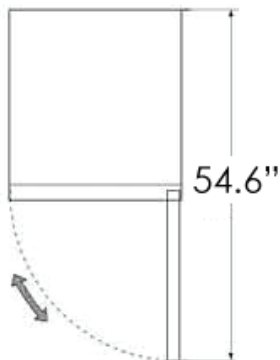
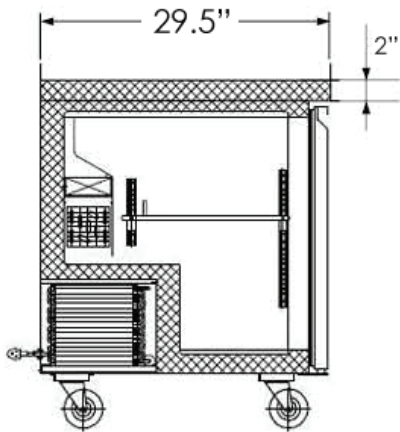
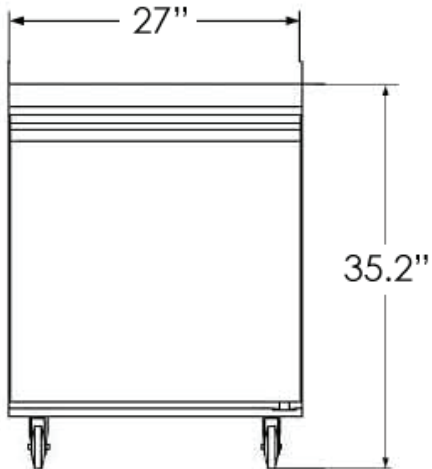

TECHNICAL SPECIFICATION

Item	59054
Model	RE-CN-0006E-HC
Capacity	6.3 cu.ft. / 177 L
Number of Doors	1 Solid Door
Number of Shelves	1
Shelf Capacity (kg/pc)	44 lb. / 20 kg.
Shelf Material	Coated Steel
Self-closing Door	Yes
Power	1/6 HP
Amps	1.9 A
Electrical	115V / 60Hz / 1Ph
Temperature Controller	Digital Display
Temperature Range	5 - 0.5°C / 41°F - 33°F
Refrigerant	R290
Insulation Material	Cyclopentane
Cooling System	Ventilated
Defrosting	Automatic
Interior Dimensions (WDH)	22.2" x 22.8" x 23.5" / 565 x 580 x 597 mm
Net Weight	212 lb. / 96 kg.
Net Dimensions (WDH)	27" x 29.5" x 35.2" / 685 x 750 x 895 mm
Gross Weight	220 lb. / 100 kg.
Gross Dimensions (WDH)	30.4" x 32.6" x 38.6" / 770 x 830 x 980 mm
Plug Type	NEMA 5-15P

TECHNICAL DRAWING

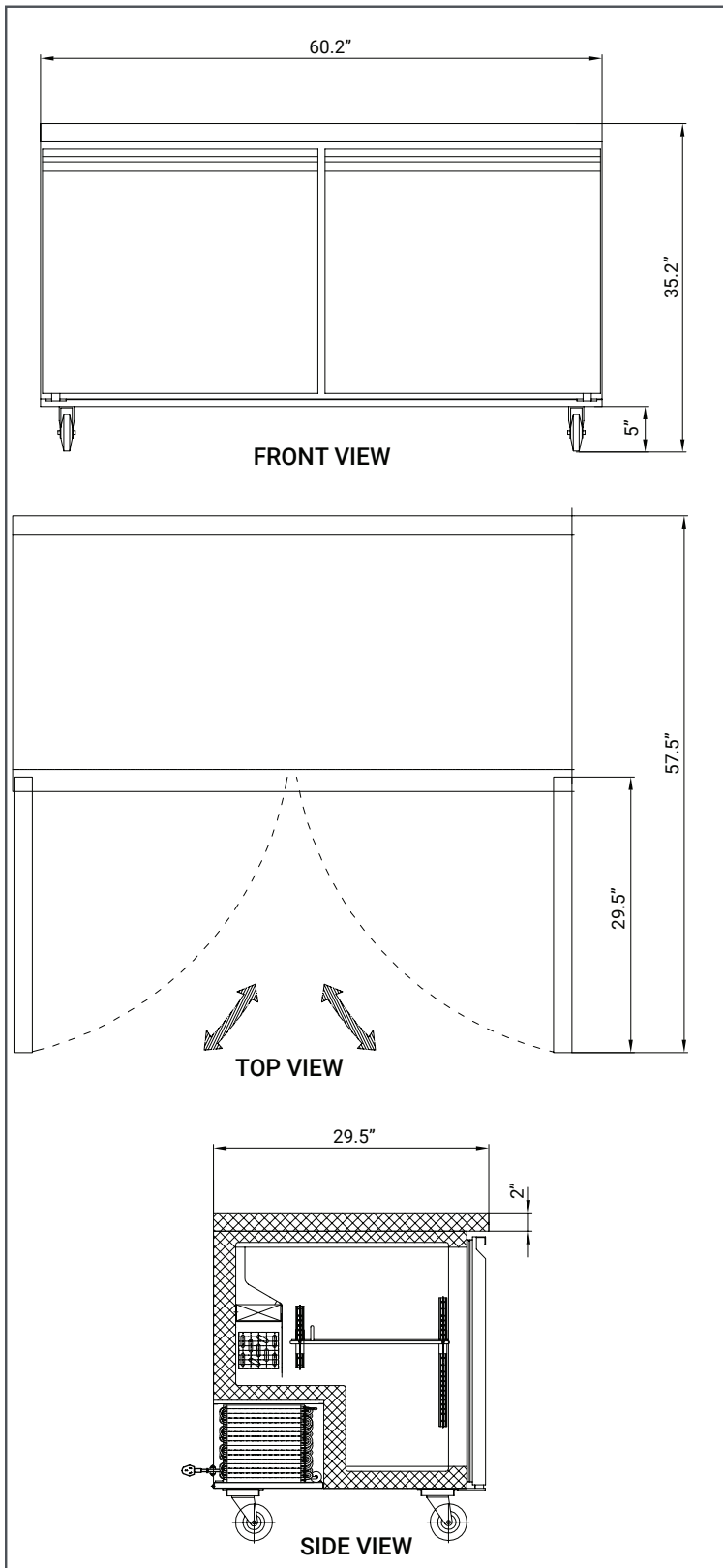

TECHNICAL SPECIFICATION

Item	59093
Model	RE-CN-0015E-HC
Capacity	15 cu. ft. / 425 L
Number of Doors	2 Solid Doors
Number of Shelves	2
Shelf Capacity (kg/pc)	88lb. / 40kg.
Shelf Material	Plastic Coated
Self-closing Door	Yes
Power	285 W
Amps	2.6 A
Electrical	115V / 60Hz / 1Ph
Temperature Controller	5 ~ 0.5°C / 41° ~ 33°F
Temperature Range	Digital Display
Refrigerant	R290
Insulation Material	Cyclopentane
Cooling System	Ventilated
Defrosting	Automatic
Interior Dimensions (WDH)	55.6" X 19.84" X 23.5" / 1413 X 504 X 597 mm
Net Weight	254 lb. / 115 kg.
Net Dimensions (WDH)	60.2" X 29.5" X 38.8" / 1529 X 750 X 985 mm
Gross Weight	324 lb. / 147 kg.
Gross Dimensions (WDH)	74.2" x 32.3" x 38.2" / 1600 x 820 x 970 mm
Plug Type	NEMA 5-15P

TECHNICAL DRAWING

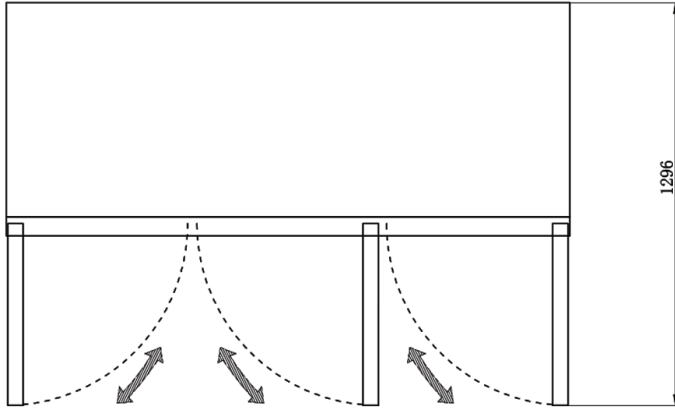

PLAN

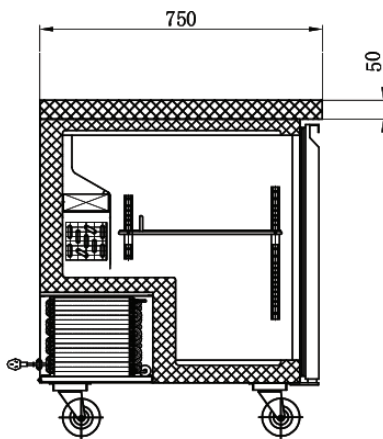
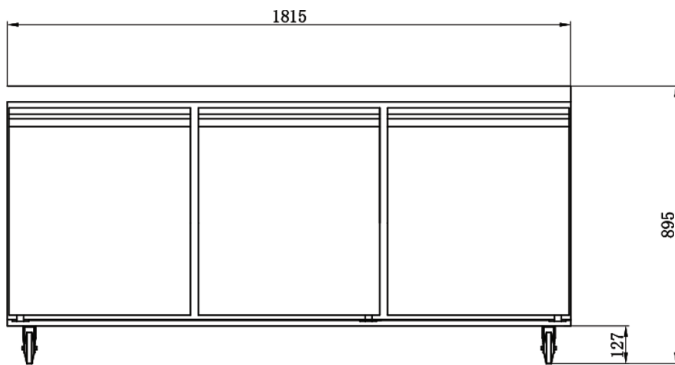

SECTION VIEW

TECHNICAL SPECIFICATION

Item	59091
Model	RE-CN-0017E-HC
Capacity	15.5 cu.ft / 440L
Number of Doors	3 Solid Doors
Number of Shelves	3
Shelf Material	Plastic Coated Steel
Shelf Capacity (kg/pc)	88 lb. / 40kg.
Self-closing Door	Yes
Power	1/5 hp
Amps	1.9 A
Electrical	115V / 60Hz / 1Ph
Temperature Controller	Mechanical / Digital Display
Temperature Range	0.5 - 5°C / 33 - 41°F
Refrigerant	R290
Insulation Material	Cyclopentane
Defrosting	Automatic
Cooling System	Ventilated
Interior Dimensions (WDH)	66.85" x 19.84" x 23.5" / 1698 x 504 x 597mm
Net Weight	297.6 lb. / 135 kg.
Net Dimensions (WDH)	72" x 29.5" x 35.2" / 1829 x 750 x 895mm
Gross Weight	372.6 lb. / 169 kg.
Gross Dimensions (WDH)	74.2" x 32.3" x 38.2" / 1885 x 820 x 970mm
Plug Type	NEMA 5-15P